

# CABLE WORKING GEAR CATALOGUE 2026/27



MC Engineering Services are specialists in the design, manufacture, repair, thorough examination and testing of lifting, lashing and mooring equipment; as well as being suppliers and manufacturers of cable working gear.

Successfully supplying equipment for over 35 years, with experience of over 45 years within this industry; MC Engineering Services are a highly reputable company and are proving to be experts in finding a solution to your load monitoring requirements. MC Engineering Services are known for an unprecedented high quality, reliable standard product range. We demonstrate leadership from our experience and skills that we provide.

MC Engineering Services work to the highest of standards and comply fully with BS EN ISO 9001:2015.

Our experienced team of Engineers and Sales Advisers can provide an economical, durable and reliable solution for you when you need it and take pride in building strong working relationships with our clients from first contact to project completion.

We have full traceability on lifting equipment supplied or manufactured and is kept on file.

#### Services we provide:

- **CNC Milling**
- **Manual Milling**
- **Turning**
- **A Frame Load Testing**
- **In-House/on site Load Testing**
- **The Design & Modification of Components for specific requirements**
- **NDT - Non-Destructive Testing (PCN Level II)**
- **Thorough Examination, Load Test and MPI of new & in-service Twistlocks**
- **Specialising in the manufacture & supply of all Cable Working Gear i.e. grapnels for clearance & recovery work (catalogue available soon)**
- **Load monitoring equipment (saddle backs, load cells, running line monitors etc.)**

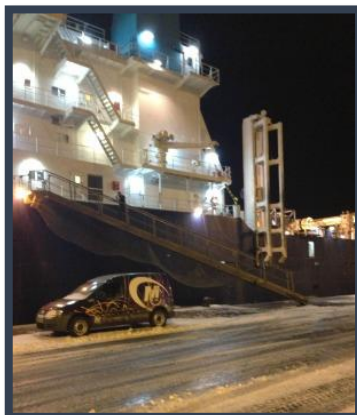

# Index

	<u>PAGE</u>
SG Flatfish	4
SG Flatfish Accessories	6
PL 26t SG Gifford	7
26t Rennie	9
9t Boat Rennie	11
Sandpoint Grapnel	12
Spearpoint Grapnel	14
Detrencher Grapnel	16
Cut & Hold Grapnel - CHG	18
Sliding Prongs	19
Son of Sammy (Folding)	21
7.5t BPO Cutting Hook	23
5t SG Cutting Hook	23
Mushroom Anchors	25
Repeater Trolley	27
BTL Stopper	29
Taper Roller Bearing Combination Swivel	31

## SG Flatfish

	Part No	A1 (mm)	A2 (mm)	B (mm)	C (mm)
SG Flatfish (long prong)	SGFLP1	1010	-	750	1000
SG Flatfish (short prong)	SGFSP1	-	750	750	1000

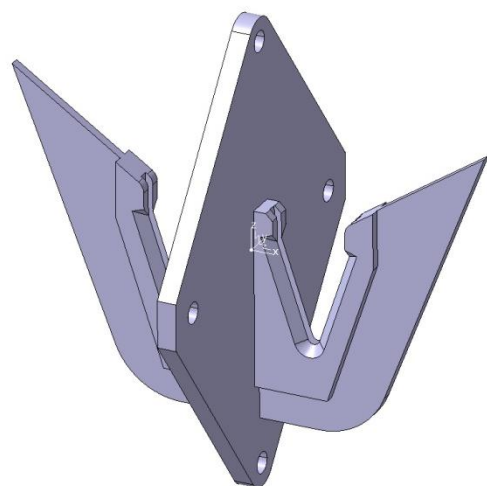
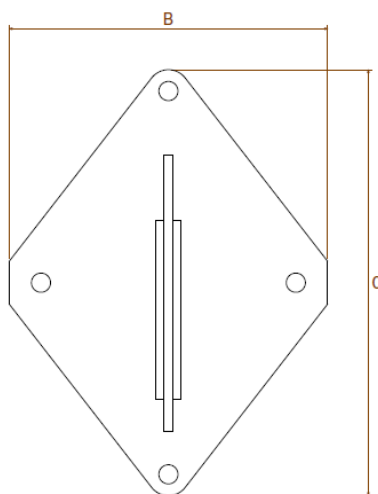
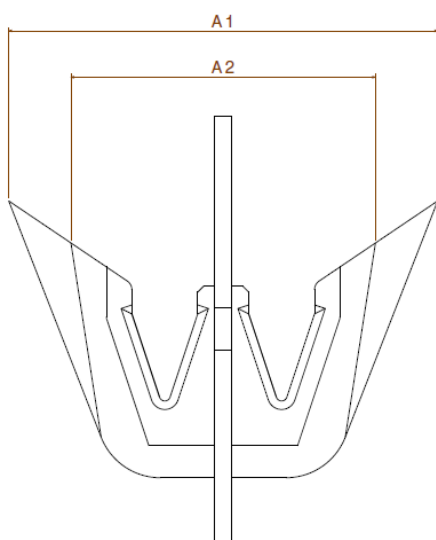

**Stock held, 2 of each, subject to demand**

## SG Flatfish Description

The Flatfish Grapnel consists of a diamond-shaped plate with two prongs 90 degrees of the plate & blade holders at the base of the prongs. Designed to also take a holding glove.

It is useful in all depths on sandy or easily disturbed seabeds. Short or long prongs supplied depending on required penetration.

### Key features

- **Manufactured from high strength structural steel**
- **Machined blade holders for accurate fitment**
- **Shearpin holder for Armoured Cable cutting diameters 16mm – 45mm**
- **Designed to use with holding gloves**
- **Painted - Red Oxide**

### Applications

- **PLGR (Pre Lay Grapnel Run)**
- **Designed for use in all water depths on soft or smooth seabeds**
- **Cutting cable when fitted with blades, curved blades for lightweight cable, straight blades for armoured cable 16mm – 45mm diameter**
- **Recovering cable when fitted with gloves**
- **Maintenance of cable systems**

## SG Flatfish Accessories

	Part No	A (mm)	B (mm)	C (mm)
SG Glove	SGG	400	215	240
SG Armoured Blade	SGS	278	180	25
SG Lightweight Blade	SGC	270	180	25

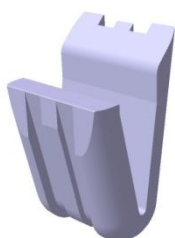
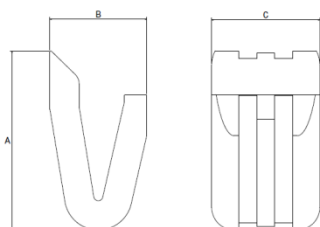

Glove for SG Flatfish

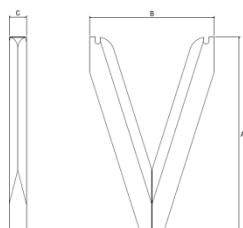

Armoured Blade for SG Flatfish/  
Cutting Hook

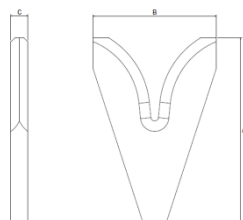

Lightweight Blade for SG Flatfish/  
Cutting Hook

Stock held, 2 of each, subject to demand

## PL 26t SG Gifford

	Part No	A (mm)	B (mm)	C (mm)
PL 26t SG Gifford	SG26	2520	614	177
PL 34t Gifford	SMALL34	2020	464	148

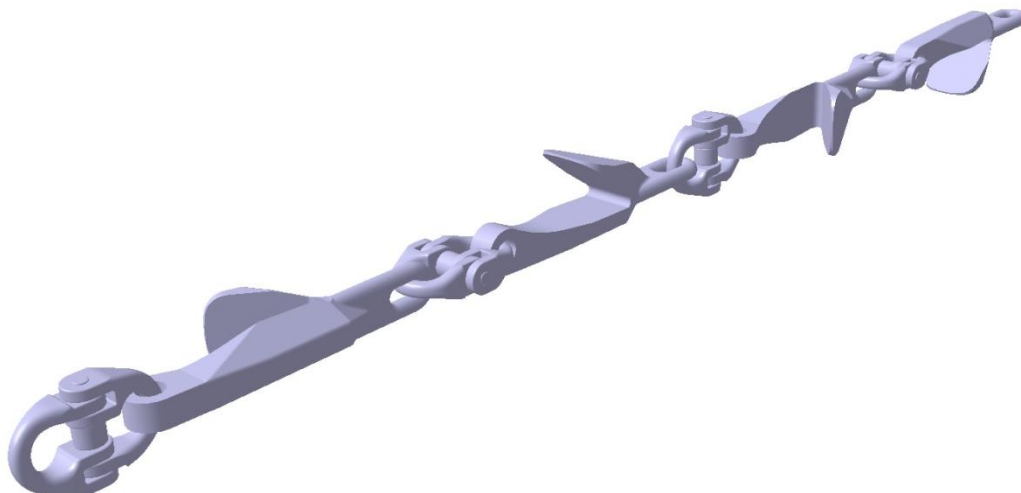
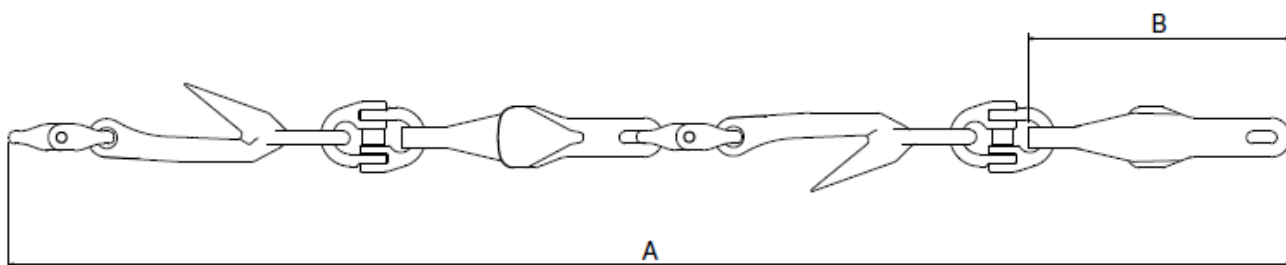

Stock held, 2 of each, subject to demand

01489 878769 ■ sales@mcengineeringsservices.com ■ www.mcengineeringsservices.com



## PL 26t SG Gifford Description

The Gifford Grapnel can be used in conjunction with the Rennie grapnel. It is made up in units of four hooks at right angles to each other. The hooks have a broad hook seat to form a cup to hold the hooked cable. It can be used on any type of seabed. Though originally designed for rocky or coral environments.

### Key features

- Cast from high strength alloy
- Casting removes any sharp edges which could damage cables
- Each grapnel is proof tested to ensure strength

### Applications

- PLGR (Pre Lay Grapnel Run)
- Designed for rocky or coral environments
- Recovering and clearing cables up to 90mm diameter (Large Gifford) and 51mm diameter (Small Gifford)
- Maintenance of cable systems
- Painted – Red Oxide

## 26t Rennie

	Part No	A (mm)	B (mm)	C (mm)	D (mm)
26t Rennie	SGR26	2706	660	400	428

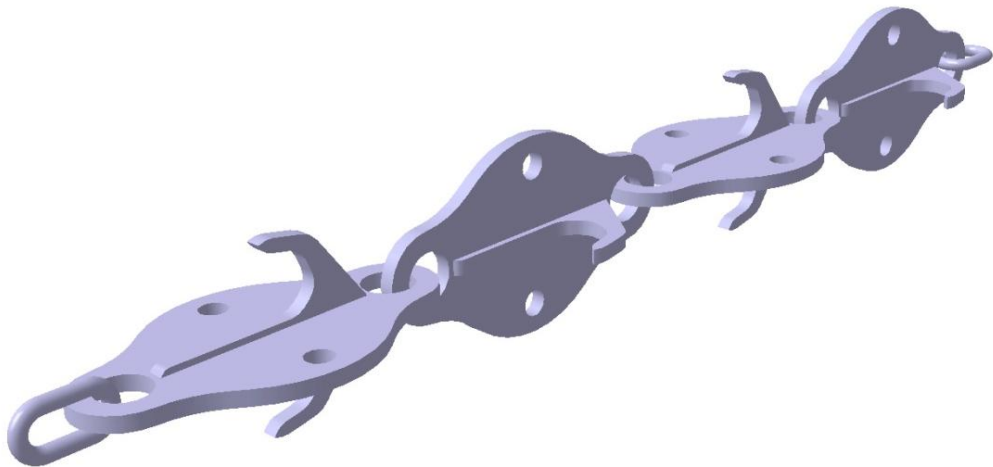
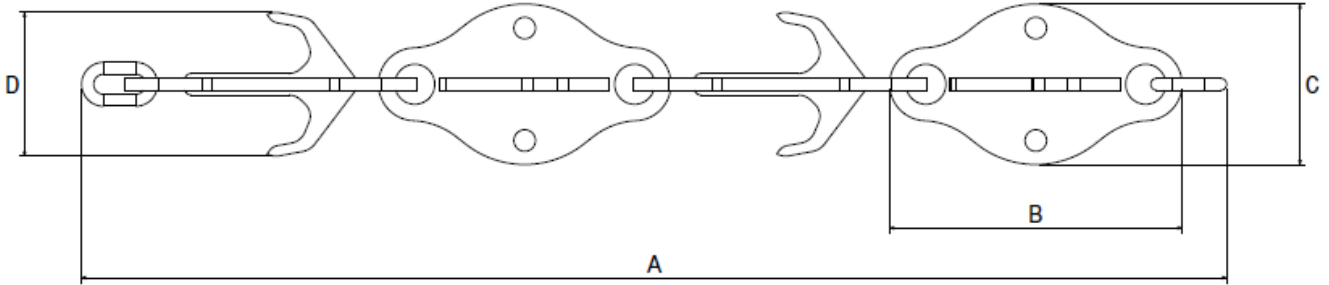

Stock held, 2 of each, subject to demand

## Rennie Description

The Rennie Grapnel is joined together in sets of four hooks 90 degrees to each other in the form of a chain.

Originally designed for rocky environments.

Two types available Small & Large. Often used within a grapnel train.

### Key features

- **Manufactured from high strength structural steel**
- **Proof Load applied to each hook back to the tow point**
- **Paint – Red Oxide**
- **Small & Large Rennie Grapnel's available**

### Applications

- **PLGR (Pre Lay Grapnel Run)**
- **Any seabed environment**
- **Recovering or clearing cables up to 90mm diameter**
- **Maintenance of cable systems**
- **Used in conjunction with a grapnel train**



## 9t Boat Rennie

	Part No	A (mm)	B (mm)	C (mm)
9t Boat Rennie	BR9	1670	398	245

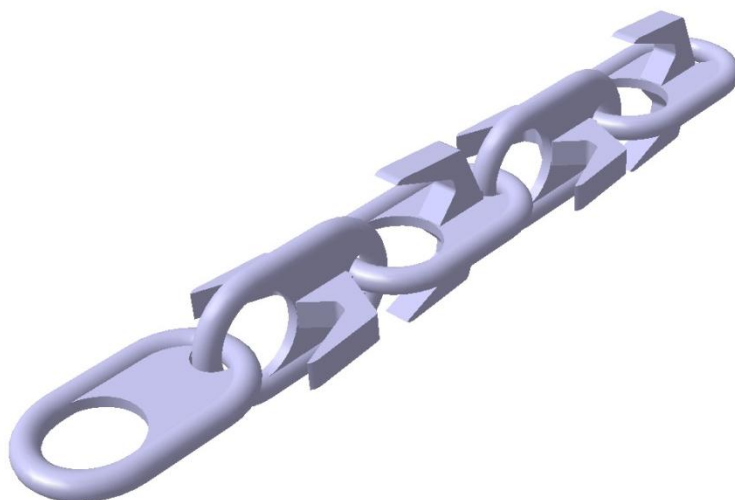
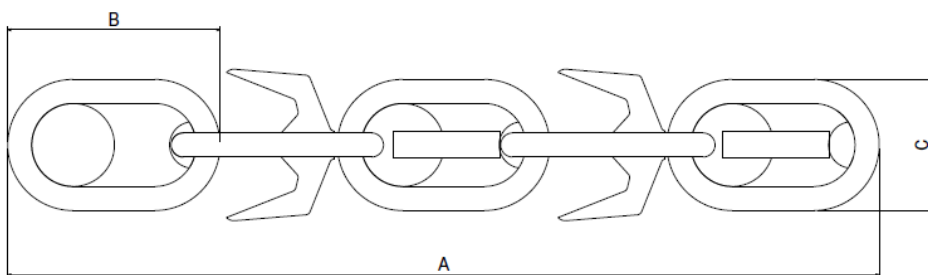

Stock held, 2 of each, subject to demand

01489 878769 ■ sales@mcengineeringervices.com ■ www.mcengineeringervices.com



## Sandpoint Grapnel

	Part No	A (mm)	B (mm)	C (mm)
115kg	SA115	950	385	330
180kg	SA180	1220	510	470
250kg	SA250	1550	560	550

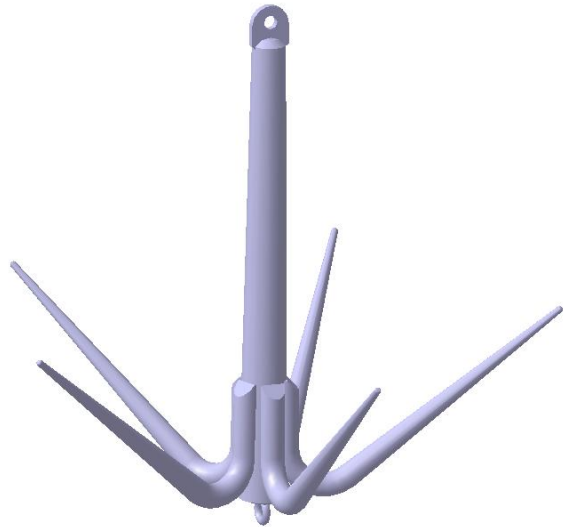
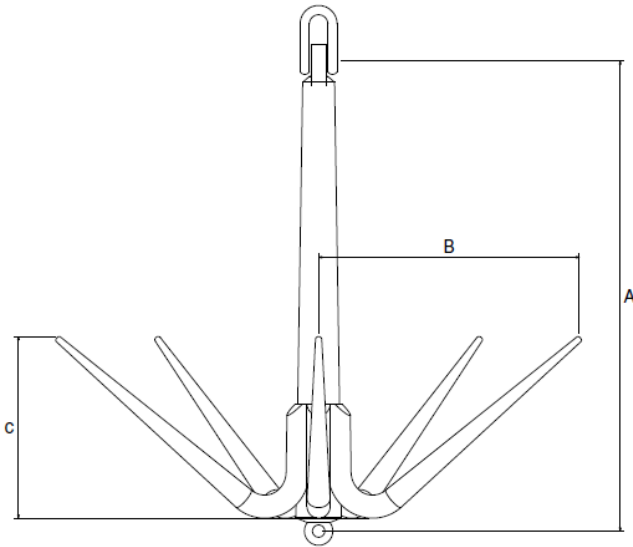

Stock held, 2 of each, subject to demand

01489 878769 ■ sales@mcengineeringsservices.com ■ www.mcengineeringsservices.com



## Sandpoint Grapnel Description

The Sandpoint Grapnel is manufactured from high strength structured & alloy steel. Consists of a shank with five prongs with tapered prongs.

The standard sizes normally used are 115kgs, 180kgs and 250kgs. The size also determined for penetration requirements.

They are ideal for use on sandy or easily disturbed seabeds where little resistance will be experienced. They are particularly good where the cable has become self-buried.

Also used in conjunction with the Rennie & Gifford in a grapnel train. They are often added at the rear of the grapnel train for extra weight and penetration.

### Key features

- Manufactured from high strength structural / alloy steel
- Integrated single piece prongs for increased strength
- Prongs are Individually proof loaded to the tow point
- Painted – Red oxide

### Applications

- PLGR (Pre Lay Grapnel Run)
- Designed for sandy seabed environments
- Recovering or clearing self buried cable
- Maintenance of cable systems

## Spearpoint Grapnel

	Part No	A (mm)	B (mm)	C (mm)
115kg	SP115	900	385	300
180kg	SP180	1220	410	320
250kg	SP250	1550	450	375

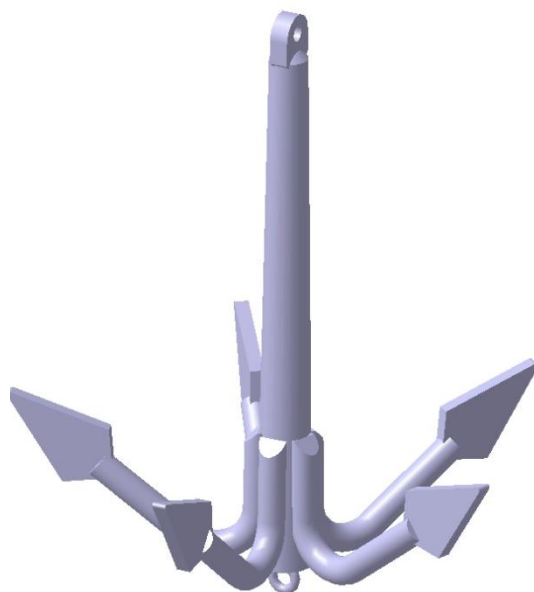
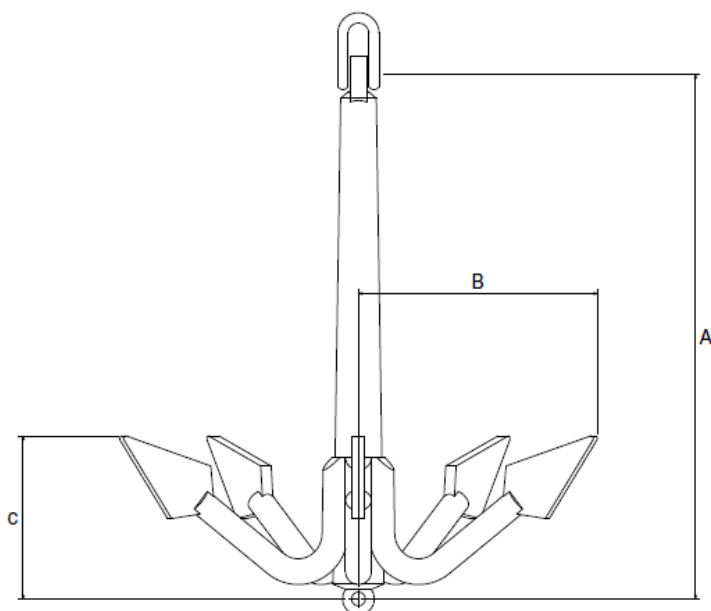

**Stock held, 2 of each, subject to demand**

01489 878769 ■ sales@mcengineeringervices.com ■ www.mcengineeringervices.com



## Spearpoint Grapnel Description

The Spearpoint Grapnel is manufactured from high strength structured & alloy steel. Consists of a shank with five prongs with reinforced tips.

The standard sizes normally used are 115kgs, 180kgs and 250kgs. The size also determined for penetration requirements.

They are ideal for use on sandy or easily disturbed seabeds where some resistance will be experienced. They are particularly good where the cable has become self-buried.

Also used in conjunction with the Rennie & Gifford in a grapnel train. They are often added at the rear of the grapnel train for extra weight and penetration.

### Key features

- Manufactured from high strength structural / alloy steel
- Integrated single piece prongs for increased strength
- Prongs are Individually proof loaded to the tow point
- Painted – Red oxide

### Applications

- PLGR (Pre Lay Grapnel Run)
- Designed for sandy seabed environments
- Recovering or clearing self buried cable
- Maintenance of cable systems

## Detrencher Grapnel

	Part No	A (mm)	B (mm)	C (mm)
Penetration Depth 1	DTG1	2835	1830	670
Penetration Depth 2	DTG2	2835	2650	1007
Penetration Depth 3	DTG3	3960	3600	1500

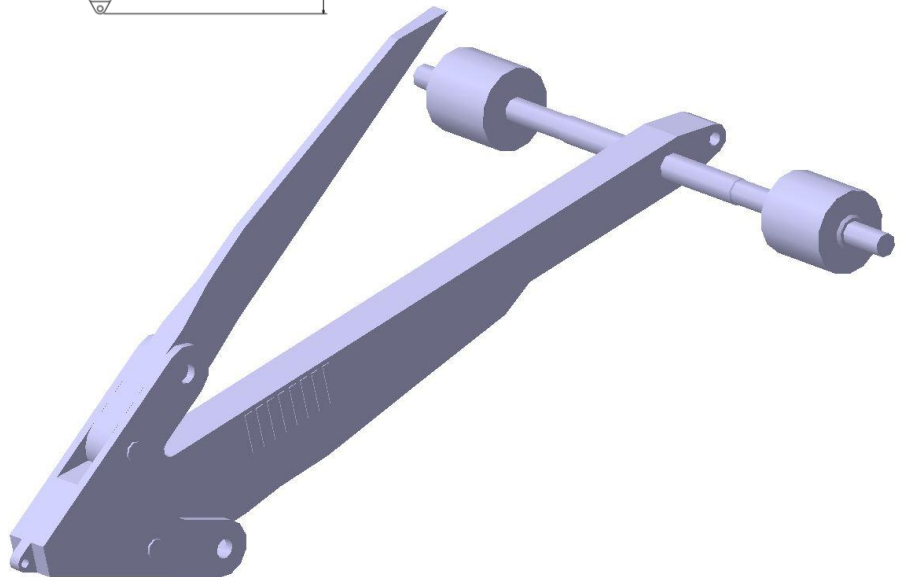
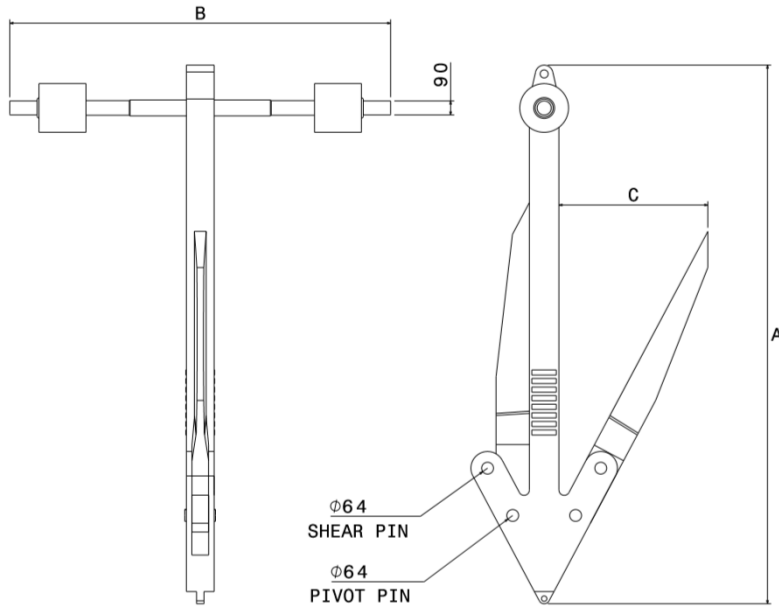

## Detrencher Grapnel Description

The Detrenching Grapnel is manufactured from high tensile steel, suitable for withstanding the harsh offshore environments.

The Grapnel itself is scissor shaped at one end, which is designed to break the surface of the seabed and fitted with stabilising bars at the other end, to assist its dynamic use being lowered in the correct orientation & stability on the seabed. Optional fitment of two Tynes if required either side of the grapnel, Tynes are removable & supplied in different lengths depending on required penetration depth required.

The grapnel, has been designed to withstand tow tensions of up to 20t. It has a built in shear pin rated to a breaking load that will shear protecting the grapnel. Shearpins can be supplied to suit the load requirement for the project.

### Key features

- Manufactured from high strength structural steel
- Removable shear pin to prevent damage in overload conditions
- Wide stabiliser to improve subsea stability & removable for storage
- Painted – Red Oxide or White RAL

### Applications

- Detrenching buried subsea cables (Power or telecoms)
- Subsea cable recovery for repair
- Removal of out of service cables
- Route Clearance

## Cut & Hold Grapple - CHG

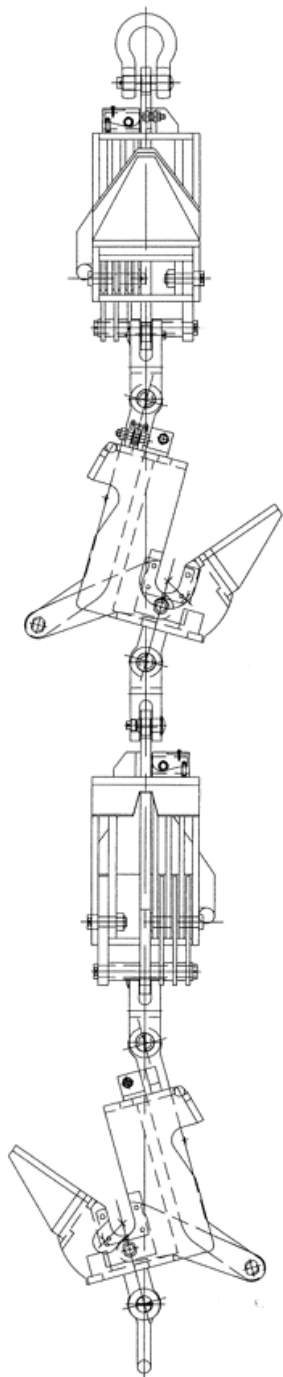

### Capacity:

Load at the beginning of cutting – 3t (Shear Pin to be broken)

### Cutting:

2-5t

### Holding:

3-6t

### SWL:

≤8t

*These figures depend on the shapes of cables.*

## Sliding Prongs

	Part No	A (mm)	B (mm)	C (mm)
Type A (4 Prongs)	SPA	1730	400	350
Type B (3 Prongs)	SPB	1730	700	550
Type C (2 Prongs)	SPC	1730	1000	880

**NB: Shank proof loaded to 10t**

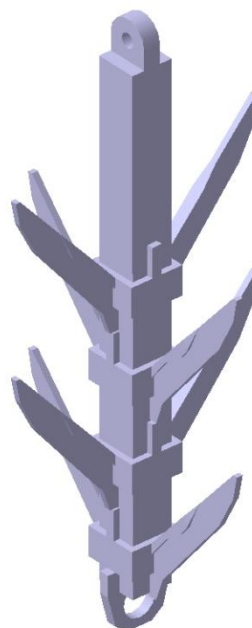
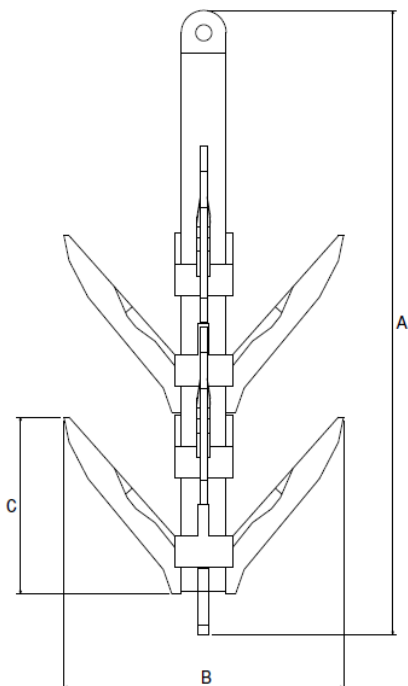

**Stock held, 2 of each, subject to demand (Type C Prong only)**

## Sliding Prong Grapnel Description

The sliding Prong Grapnel comprises a square cross-section shank on which prongs slide on in alternate directions. Broken or damaged prongs can be slipped off and replaced. Prongs are in three sizes/types, known as Type A (Small), Type B (Medium) and Type C (Large).

### Key features

- Manufactured from high strength structural steel
- Rounded edge on wings to support/protect cable
- Removable/replaceable prongs in the event of damage
- Painted – Red Oxide

### Applications

- PLGR (Pre Lay Grapnel Run)
- Designed for use over sand, clay or mud seabeds
- Recovering or clearing cables which are buried
- Maintenance of cable systems

## Son of Sammy (Folding)

	Part No	A (mm)	B (mm)	C (mm)
Son of Sammy (Folding)	SOSF	2300	2020	950

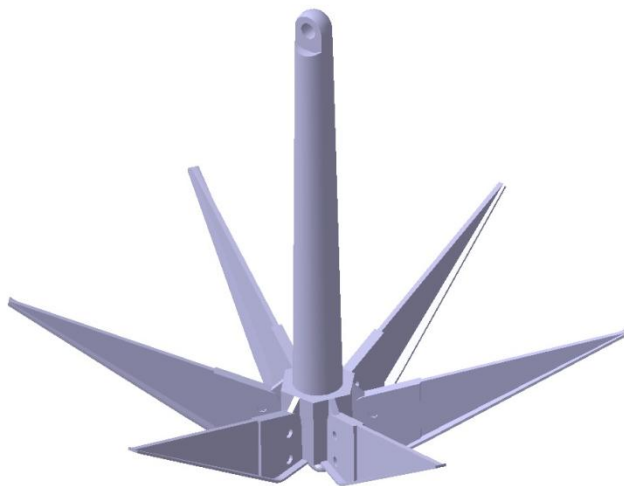
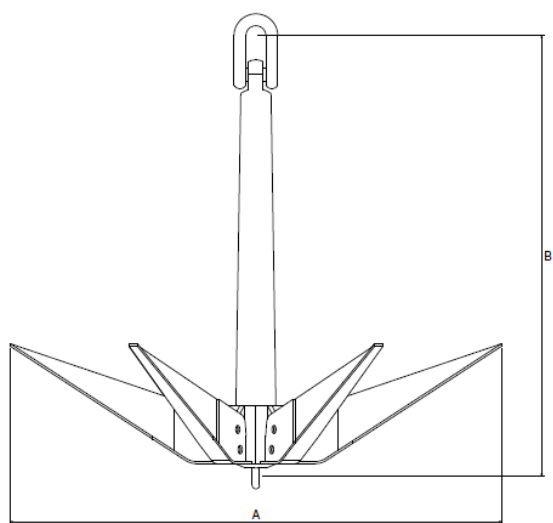

## Son of Sammy Description

A round bottom grapnel consisting of six prongs position centrally around a main shank. Its design being based on the original long prong sand grapnel.

It can be manufactured with fixed prongs or folding where the prongs can be stowed during periods of non-use. Due to the design the prongs provide increased holding capacity during operations.

### Key features

- One metre plus penetration
- Can be used in clay and sand type seabed
- Multi prong design provides increases percentage of cable recovery
- Two types available, fixed and folding
- Painted – Red Oxide or RAL White

### Applications

- Recovery of buried cables in a variety of seabeds

## 7.5t BPO Cutting Hook

	Part No	A (mm)	B (mm)
7.5t BPO Cutting Hook	CH7.5	510	275

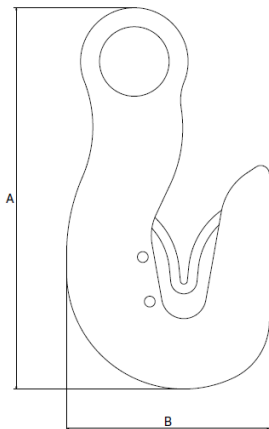

## 5t SG Cutting Hook

	Part No	A (mm)	B (mm)
5t SG Cutting Hook	R5	1352	398

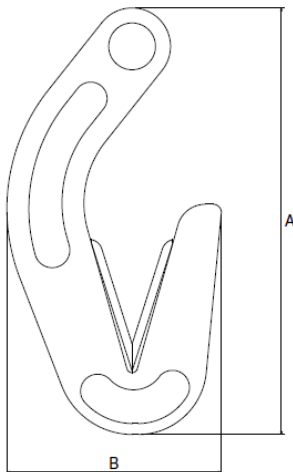

## Cutting Hook Description

A High Tensile steel holder for the Second Generation Flatfish type cutting blades (curved or straight) with a single lifting eye.

Alternate cutting device for armoured / lightweight cables.

### Key features

- Lightweight design
- Uses standard cutting blades from SG Flatfish Grapnel
- Paint - Red Oxide

### Applications

- Cutting of cable 16mm – 45mm diameters

## Mushroom Anchors

	Part No	A (mm)	B (mm)	C (mm)
250kg	MA250	Ø730	245	988
350kg	MA350	Ø750	265	988
500kg	MA500	Ø750	330	988

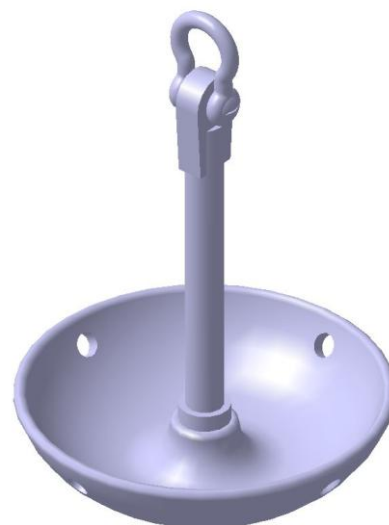
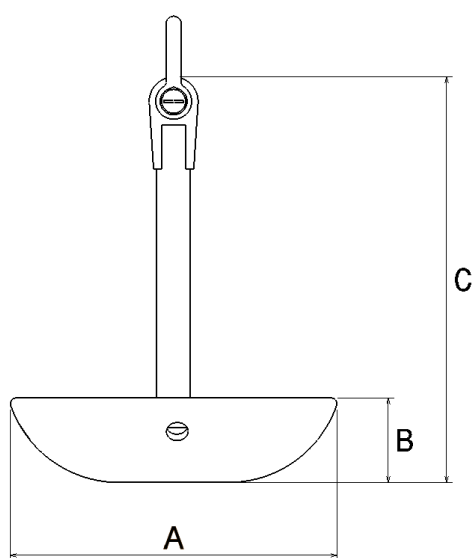
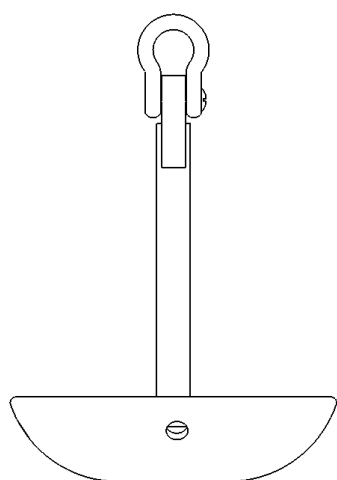

**Material:** High tensile steel  
**Finish:** Painted (red oxide)  
**Remark:** A Mushroom Anchor to suit 13.5t Shackle

01489 878769 ■ sales@mcengineeringsservices.com ■ www.mcengineeringsservices.com



## Mushroom Anchor Description

A round bottom weighted anchor at end of a central shaft. The bowl having a hole for fitment of a shackle or a wire to assist recovery.

The design of the mushroom anchor it to displace a section of the seabed equal to its own weight, providing increased holding power through weight & suction combined.

### Key features

- Variety of sizes available
- Proven design
- Easily recovered
- Supplied in a variety of weights

### Applications

- Buoy Moorings
- Additional weight during cable operations
- Protection of pre-laid cables

## Repeater Trolley

	Part No	A (mm)	B (mm)	C (mm)	D (mm)
Repeater Trolley	RT1	1000	461	300	295

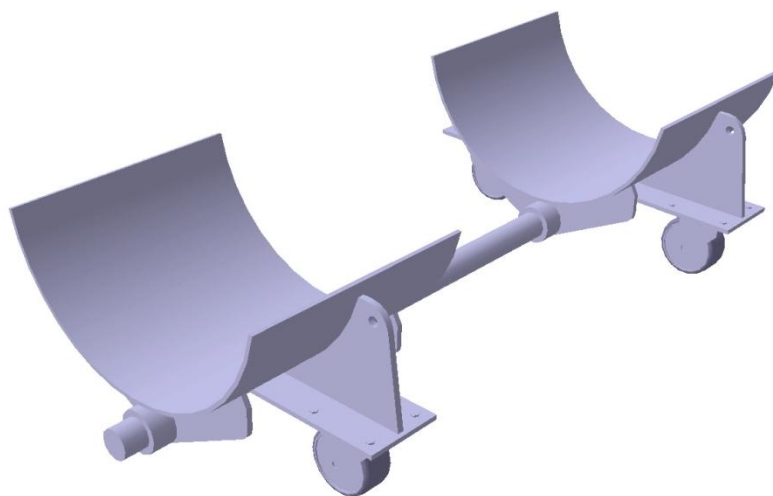
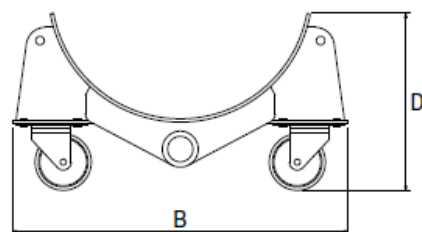
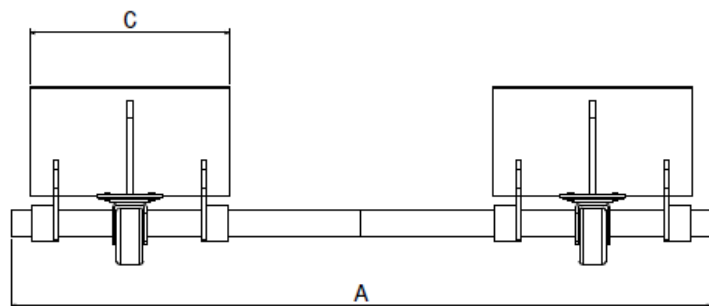

## Repeater Trolley Description

A wheeled device with either rubber faced circular or vee shaped receptacles to safely hold the repeater during cable operations.

The hollow section of the trolley allows the repeater to be moveable, secure & lifted during operations.

### Key features

- Design allows for different diameter repeaters to be used
- Free moving unit due to the castors positioned in each corner
- Moveability, Securing & Lifting of the repeater
- Paint - Red Oxide

### Applications

- Assisting safe secured movement of the repeater around the ship during deployment or recovery operations
- Storage of repeater

## BTL Stopper

	WLL	FOS	Part No	A (mm)	B (mm)	C (mm)
BTL Stopper	7t	6:1	BTLS	70	75	50

**REFERENCES:**

BRITISH TELECOMS PLC  
 BT (MARINE) LIMITED  
 DRAWING No M3 SUB/LS 464

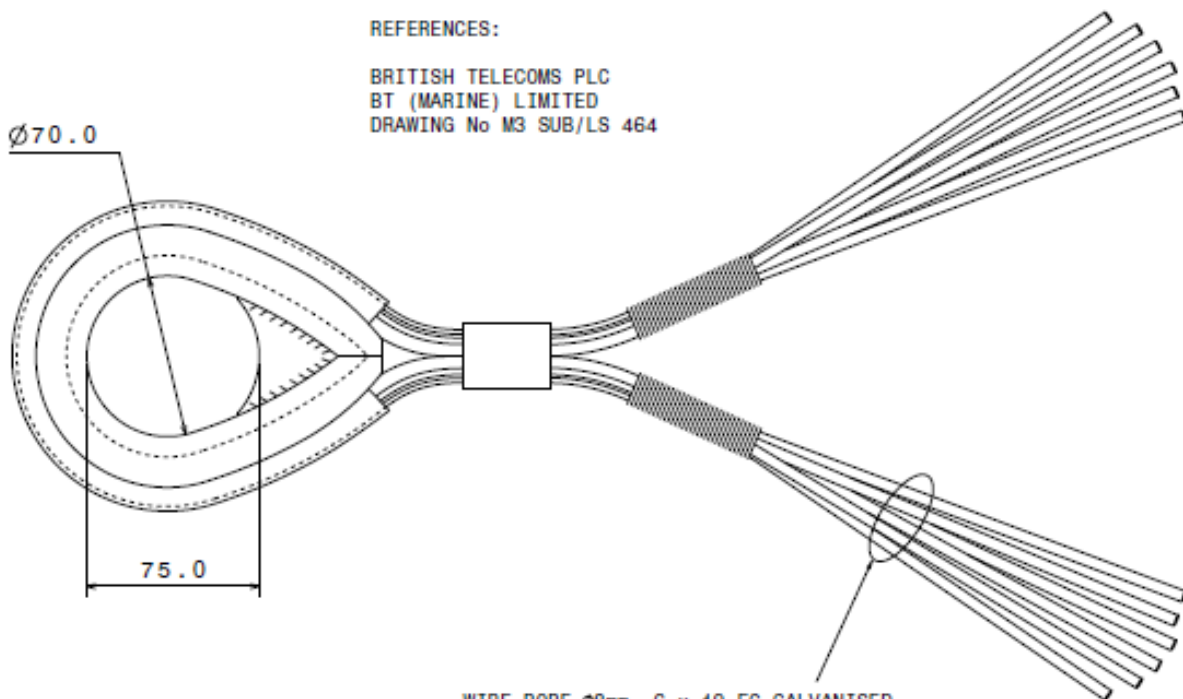

WIRE ROPE  $\phi 8$ mm, 6 x 19 FC GALVANISED  
 ENDS TAPERED AND FUSED.  
 TEST CERTIFICATE FOR WIRE ROPE TO BE SUPPLIED.  
 2 - WIRES X 6000mm  
 2 - WIRES X 8000mm  
 2 - WIRES X 10000mm } LEGS TO BE EQUAL LENGTH  
 ABOUT THIMBLE

Stock held 20 off, subject to demand

01489 878769 ■ sales@mcengineeringsservices.com ■ www.mcengineeringsservices.com



## **BTL Stopper Description**

The BTL Stopper is a 12 leg wire rope stopper with an WLL of 7t. Designed for use with all types of armoured cable. Though also used on polyurethane sheathed cable.

Construction comprises of six single lengths of 8mm diameter wire rope (2x6m, 2x8m, 2x10m) formed around a galvanised reinforced thimble & secured with a steel ferrule to allow movement of the wire legs equalising the load. Ends are fused and tapered for ease of use.

### **Key features**

- **Proven Design**
- **Used over a multitude of cable types**
- **Ease of application**

### **Applications**

- **Securing of cable ends during repairs**



# Taper Roller Bearing Combination Swivel

WLL	Part No	A (mm)	B (mm)	C (mm)
35t	SW35	620	205	525

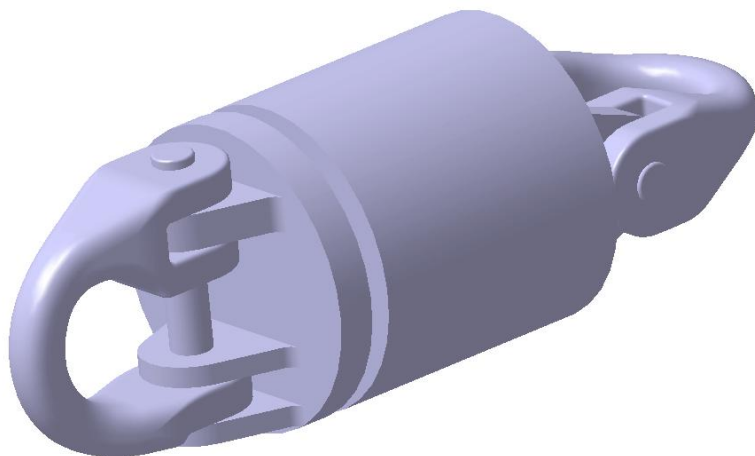
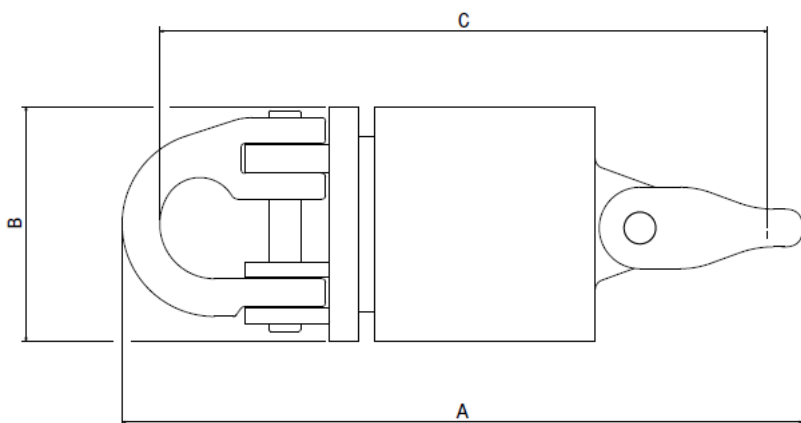

(Spare G-Link Connectors and Locking Pin sets available separately)

