



## Lever Hoist Model PROLH



### Performance

The PROLH Lever Hoist has undergone a full test program that includes:

### Type Testing

- Ultimate strength test, at least 4 times the Working Load Limit (WLL).
- Chain end anchorage test, passing at least 4 times the WLL without any restriction of the brake or gears.

### Test on every hoist

- Proof loading at 1.5 times the rated capacity.
- Light load testing at maximum of 2% rated capacity.

Product Code	Capacity (tonne)	Effort (kg)	Dimensions (mm)							Load Chain		Standard HOL (m)	Mass @ Standard HOL (kg)	Mass for Extra Metre HOL (kg)
			A	B	C	D	E	F1	F2	Diameter (mm)	No. of Falls			
PLH-0075	0.8	23	128	236	295	158	99	28	45	Ø6.3	1	1.5	7.5	0.9
PLH-0150	1.5	26	154	360	320	172	104	34	51	Ø7.1	1	1.5	10.5	1.1
PLH-0300	3	38	182	360	400	195	108	36	56	Ø10	1	1.5	18	2.2
PLH-0600	6	40	242	360	570	195	108	49	70	Ø10	2	1.5	28.5	4.3
PLH-1000	10	47	379	360	630	195	108	54	87	Ø10	3	1.5	46	6.5
PLH-1500	15	44	566	360	840	195	108	59	81	Ø10	5	1.5	112	10.8
PLH-2000	20	49	470	360	1050	250	160	81	110	Ø10	6	1.5	156	13.1



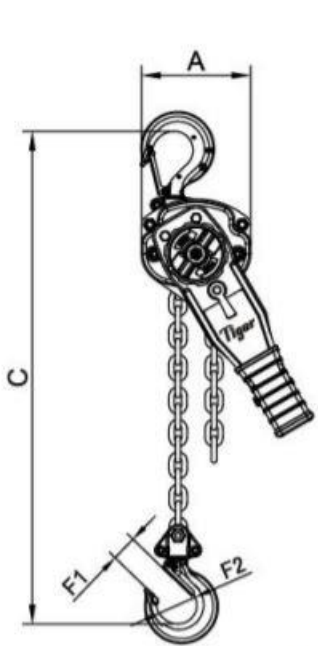

0.8t

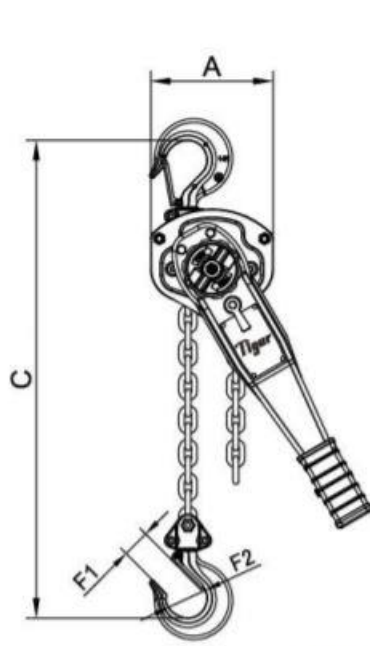
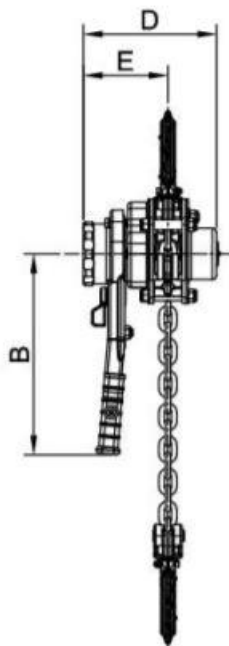

1.5t

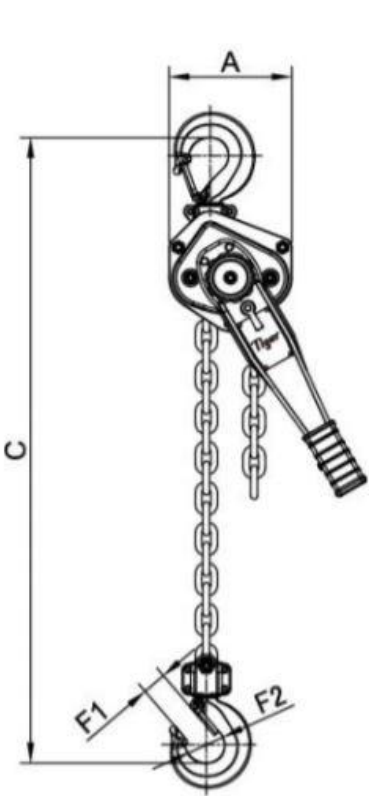
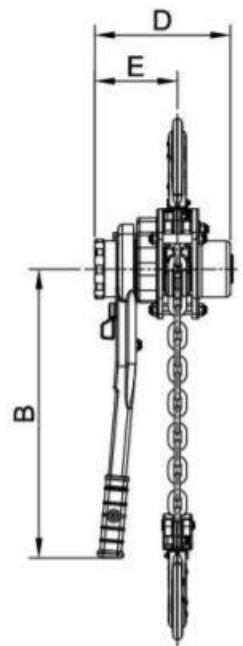

3.0t

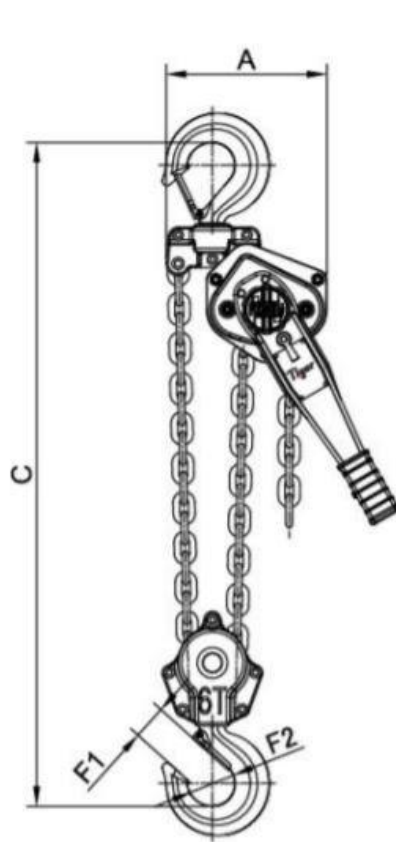
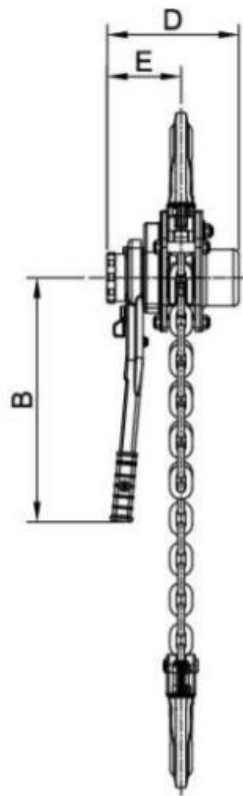

6.0t

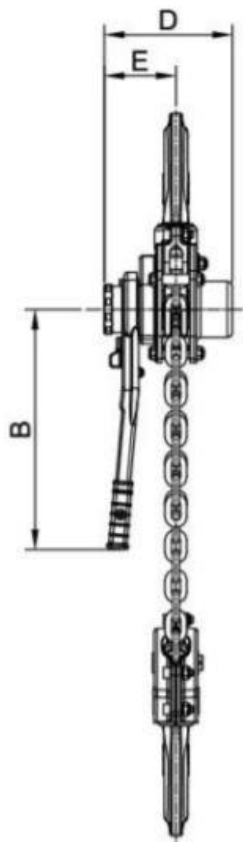

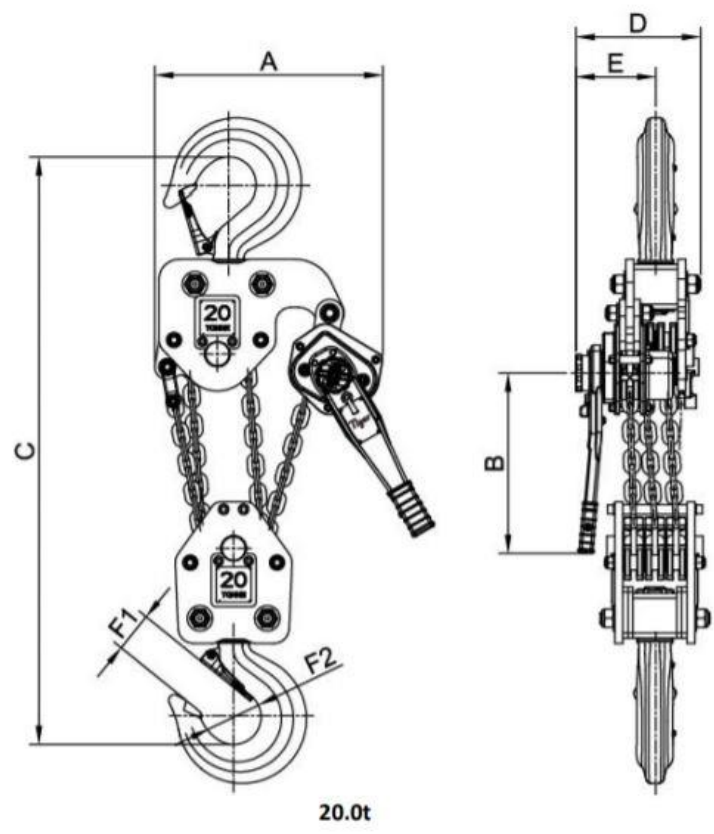
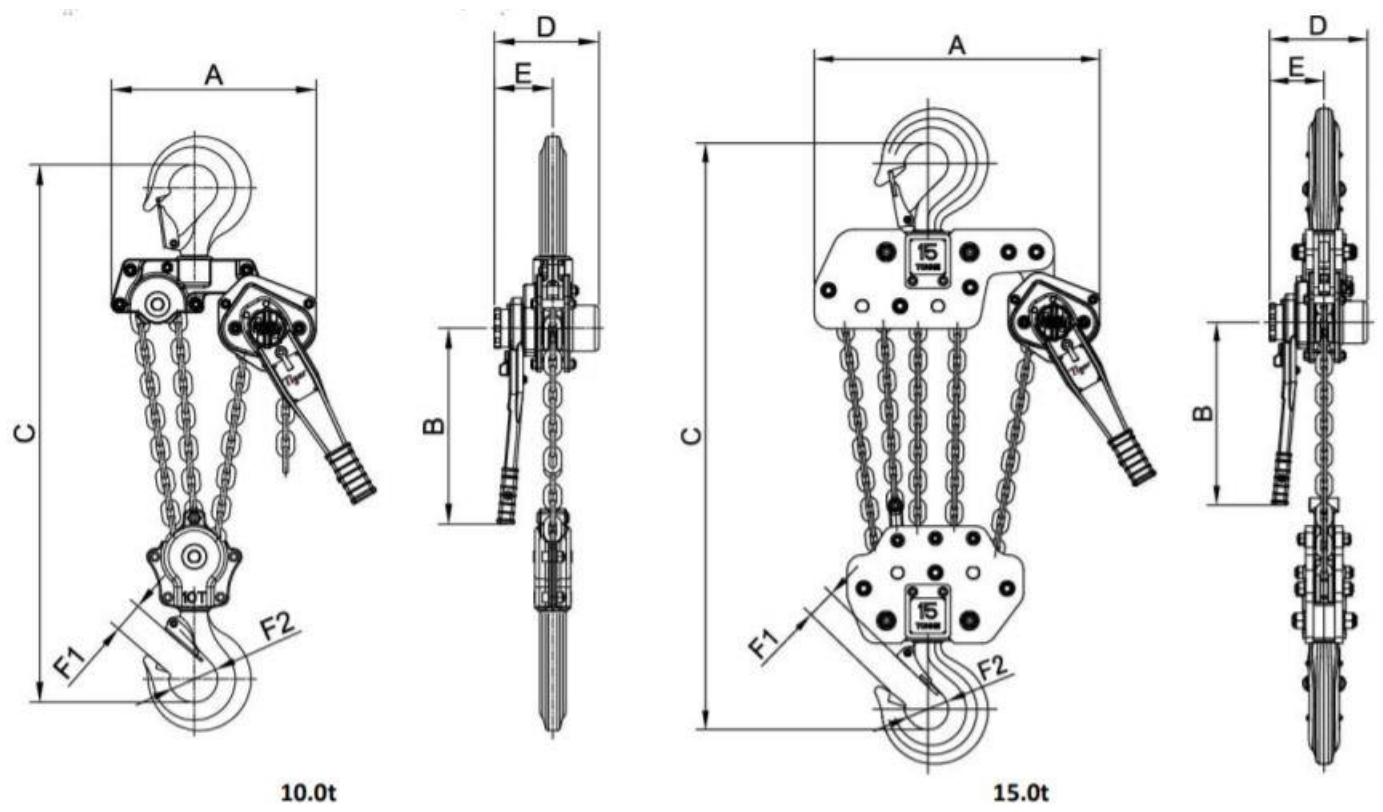

01489 878769 ■ sales@mcengineeringervices.com ■ www.mcengineeringervices.com

