

Fixed Jaw Heavy Duty Beam Clamp with Shackle Model BCF



Main Features

- Range from 1.0t to 30.0t.
- Quick and versatile rigging point for hoisting equipment.
- Shackle suspension point.
- Suitable for pulling and lifting at angles across the beam.
- Up to 90° side loading with no deration.
- 15° cross loading with no deration.
- Highly flexible – for lifting, pulling or as a semi-permanent anchor point.
- Evenly distributed loads achieved through maximum jaw surface area.
- Multidirectional adjusting screw spindle ensures a high clamping force to the various flange sizes within its capacity.
- Beam width range 75mm to 457mm.
- Operating temperature of -50°C to +50°C.
- 4:1 factor of safety.
- Optional locking device for 1t-10t (as standard on 15t-30t).

These units meet and exceed all the requirements within BS EN 13155:2003, A2:2009 and AS4991.

Certification:

Each unit comes fully certified with a test certificate or an EC Declaration of Conformity stating compliance with the essential health and safety requirements of the Machinery Directive 2006/42/EC.

No reduction in working load limits when side loads applied:

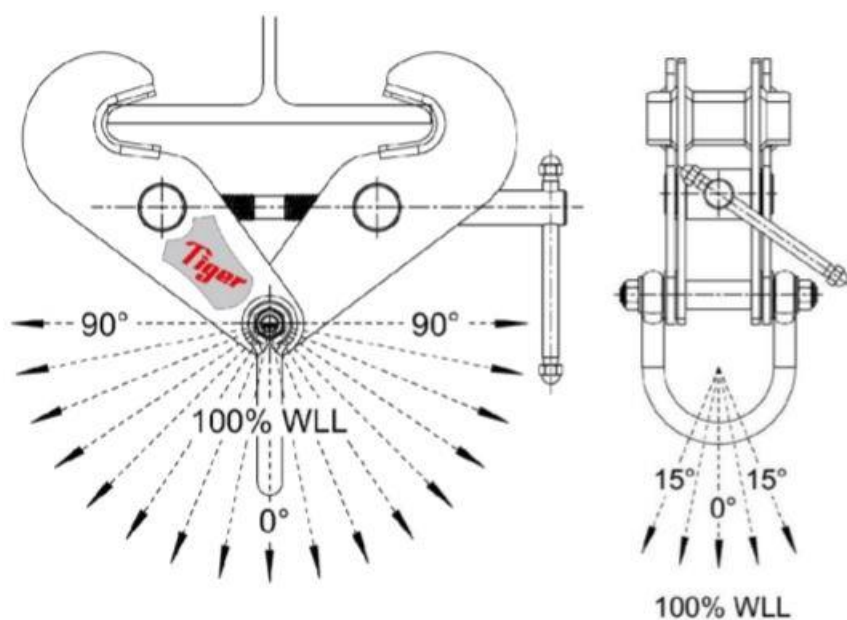

No deration up to 90° has been established for BCF model clamps and applies only for overhead beam attachments. It does not apply when used for lifting beams. Our BCF clamp has been specifically designed for this purpose.

We advise that structural calculations are carried out on all beams and supporting steelwork by qualified engineering departments to ensure safe operation.

Product Code	Capacity (tonne)	Dimensions (mm)											Net Weight (kg)	
		A	B	C	D	E	F	H	J	K	L	M		T
BCF-0100	1	75-195	206-321	105	20	190	300-266	16	21	80	84		6	5.5
BCF-0200	2	75-195	206-321	105	20	190	311-276	18	21	88	95		8	6.5
BCF-0300	3	100-350	223-476	140	25	270	418-344	22	27	110	105		10	12
BCF-030S	3	75-190	216-325	140	20	190	310-271	22	27	110	105		10	9.5
BCF-0500	5	100-310	223-438	140	25	286	424-368	27	27	124	111		12	14.5
BCF-050S	5	75-190	216-325	140	20	190	315-276	27	27	124	111		12	11
BCF-1000	10	120-350	282-511	210	30	314	460-389	32	37	83	120		16	26.5
BCF-1500	15	203-457	463-742	250	36	416	644-558	38	44	99	146	400	20	76
BCF-2000	20	203-457	471-766	300	50	416	697-609	45	49	126	179	410	25	100
BCF-3000	30	203-457	483-800	390	63	416	742-648	50	57	138	197	416	20	152

T = Beam Clamp side plate thickness / D = Maximum beam flange thickness

01489 878769 ■ sales@mcengineeringsservices.com ■ www.mcengineeringsservices.com





Technical Drawing 1t-5t:

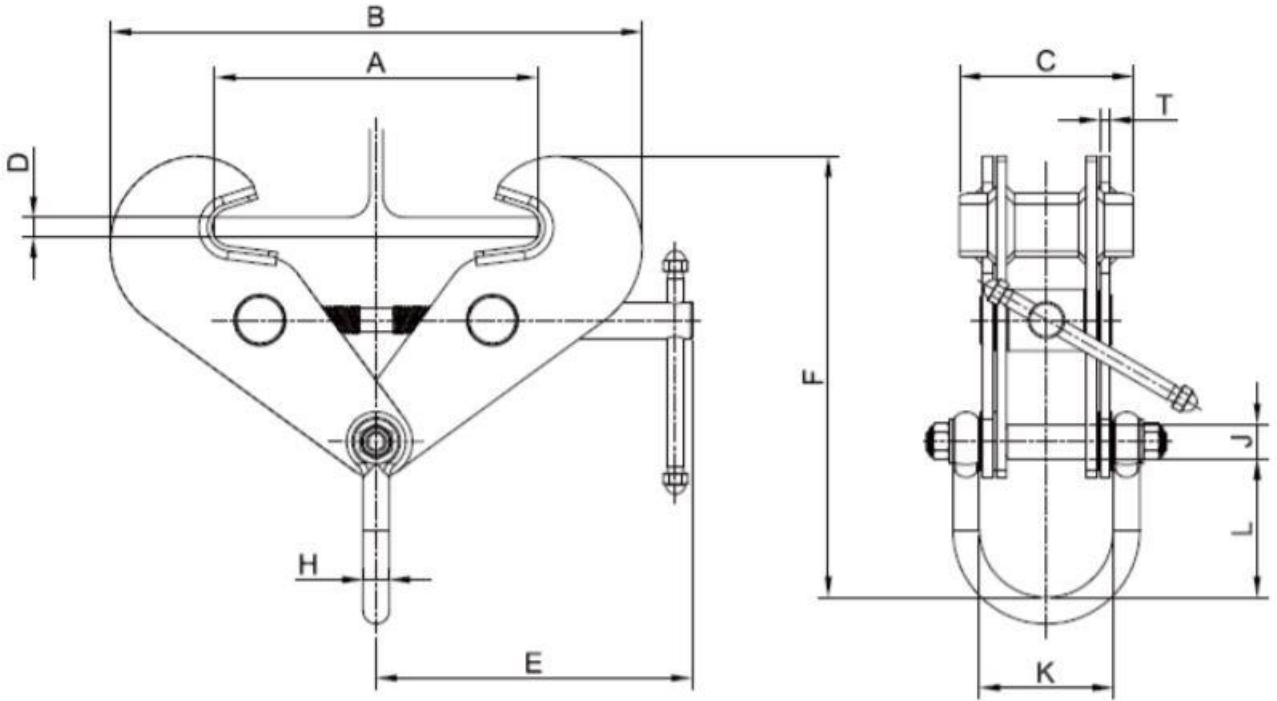

Technical Drawing 10t:

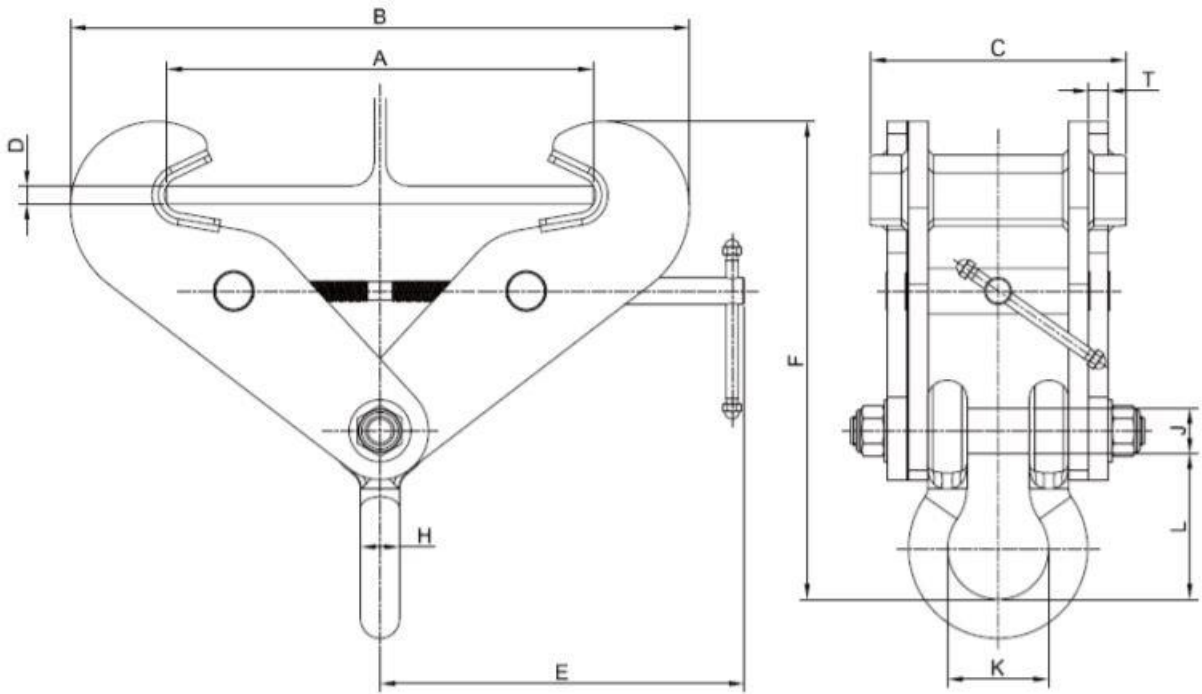



Technical Drawing 15t-20t:

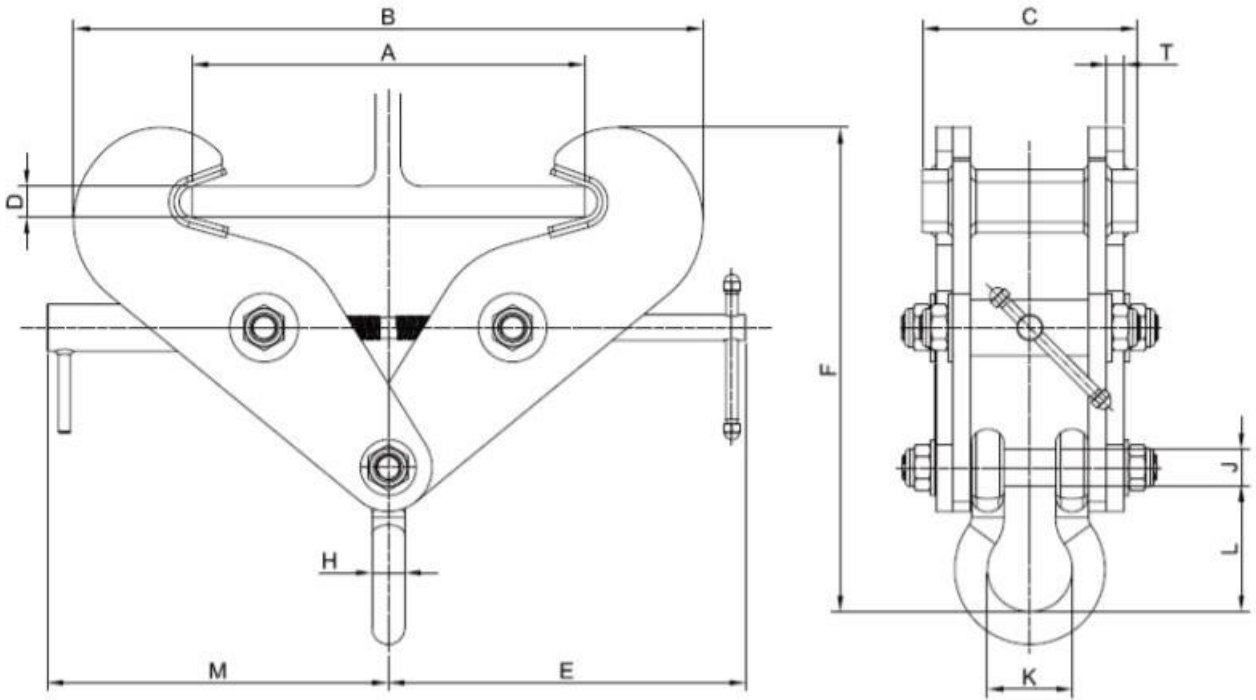

Technical Drawing 30t:

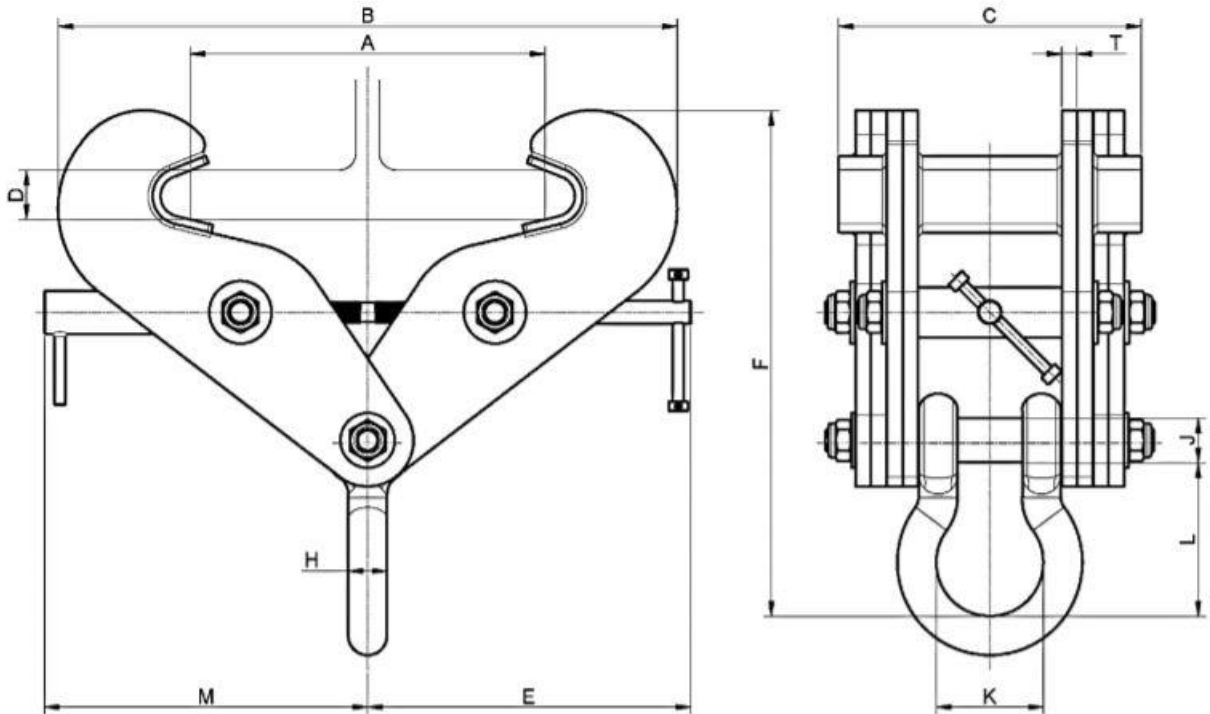

Due to continual product development, dimensions, weights and specifications may change without prior notice. Please check with our sales team when ordering.

01489 878769 ■ sales@mcengineeringervices.com ■ www.mcengineeringervices.com

